



*Steel Bar Division*

*Fence Division*

*Misc. Steel Product Division*

# About Hi-Tech

HI-TECH Fence & Steel Industry is a subsidiary of NARTEL for telecom, power and construction Company it was established in 2006 by experienced professionals based on the countries construction and security demand.

“HI-TECH” currently has 3 divisions:



## Steel Bar Division

Fabrication of high quality reinforced steel bar grade 60 with diameter range of 10mm, 12mm, 14mm, 16mm, 18mm, 20mm. Also Flat bar sizes range from 80X8mm, 70X7mm, 60X6mm, 50X5mm.



## Fence Division

offers a complete range of fence products for all types of applications, such as; chain link fence, gates, HT wire fence for expressways, welded panels and wire mesh partition systems. Whether your customer requirements are aesthetic, security or a simple repair look to HI-TECH for the best products, service and dollar value in the KSA fencing sector.



## Misc. Steel Product division:

is capable of taking any design and turning it into reality. Our custom mill employees are capable of designing and configuring any type of steel products.

## Trusted Steel Experts

No matter what industry you're working in, we have the know-how to get your job done on time. We know the industry standards you need to meet to complete your project. Hi-Tech has fabricated thousands of products for the Public, Industrial, Commercial, Architectural and Government Organizations assisting them in their miscellaneous metal requirements. We are excited about the opportunity to put our company's experienced and dedicated TEAM to work for you.

## Vision

Hi-Tech's vision is to be best manufacturing company in the region, providing customized and innovative solutions in par with international standards.

## Mission

Hi-Tech's mission includes but is not limited to;

- Produce economical quality products
- Create innovative and Hi-Tech products
- Comply with local and international standards
- Support and promote Saudization
- Achieve profitable and sustainable growth
- Comply with local laws, Industrial Health & Safety standards
- Adapt to LEAN manufacturing principles and promote growth from within

# Factory and Facilities



Hi-Tech's head office currently located in Malaz and its manufacturing facility in Al Bader District area which boasts a ~2400 Sq. Meters facility, has set up a new Head Office and manufacturing facility in Riyadh on Al Kharj Road, which now has a factory floor space of ~ 5056 Sq. Meters. Hi-Tech also commands warehousing facilities located in Azizia with a capacity of ~ 3500 Sq. Meters. With our continued growth both through our customer base and our manufacturing, Hi-Tech's long term business plans include manufacturing and warehousing facilities in each Province of The Kingdom of Saudi Arabia within the next 10 years.

## Machines Workshops

Hi-Tech Industries keeps adapting to latest and advanced manufacturing facilities in order produce high quality products at a faster and economical way. Our facilities have several machines and facilities such a Chain link Fence Machine, Barbed Wire Machine, Wire PVC Coated Machine, Powder/Epoxy Coating Plant, Power Press & Lath Machine and many more.

In this section we are showing some of our machines and workshops, however for latest list of facilities, kindly contact us.

At Hi-Tech, our Machines/workshops includes but not limited to as listed below

## Major Machines

- Chain Link Fence Machine
- Barbed Wire Machine
- Wire PVC Coated Machine
- Powder/Epoxy Coating Plant

- Power Press and Lath Machine
- For Accessories

## Welding Workshop

## General Workshop



### Chain Link Fence Machine



### Barbed Wire Machine



### Wire PVC coated Machine



### Powder epoxy Coating Plant



# Factory and Facilities >

## Major Machines Power Press and Lath Machine For Accessories



Image	Image	Image	Image	Image



## Factory and Facilities >

## Major Machines Power Press and Lath Machine For Accessories



## Factory and Facilities > Welding Workshop



Factory and Facilities > General Workshop

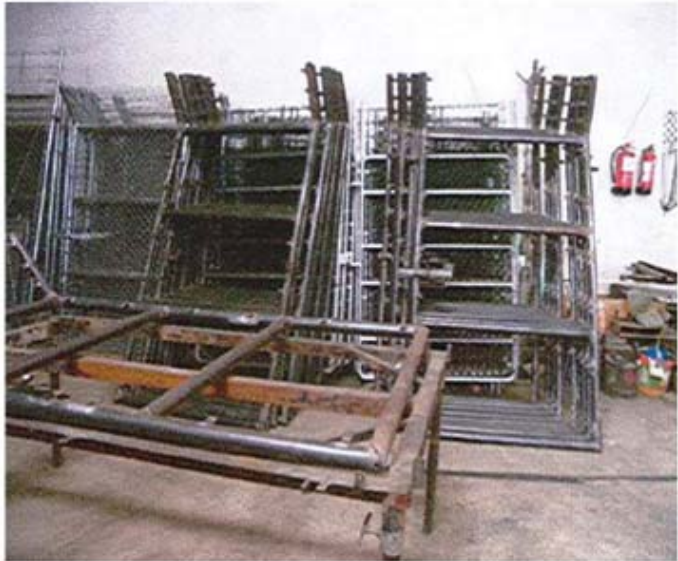



# Warehouse/ Factory License

Hi-Tech's head office currently located in Malaz and its manufacturing facility in Al Bader District area which boasts a ~2400 Sq. Meters facility, has set up a new Head Office and manufacturing facility in Riyadh on Al Kharj Road, which now has a factory floor space of ~ 5056 Sq. Meters.

Hi-Tech also commands warehousing facilities located in Azizia with a capacity of ~ 3500 Sq. Meters.

With our continued growth both through our customer base and our manufacturing, Hi-Tech's long term business plans include manufacturing and warehousing facilities in each Province of The Kingdom of Saudi Arabia within the next 10 years.



# Safety with Nartel & Hi Tech



## Safety with Nartel & Hi Tech

The safety and well being of all persons employed by NARTEL, HI-TECH is to receive first consideration throughout any and all phases of work. The prevention of occupationally induced injuries and illnesses is of such consequence that it will be given priority over operating productivity where applicable. To the greatest degree possible, management will provide all mechanical and physical facilities required for personal safety and health, in keeping with the highest standards feasible.



NARTEL, HI-TECH will maintain a Safety and Health Program conforming to the best practices. To be successful, such a program must have the cooperation in all safety and health matters, not only between supervisor and employee, but also between each employee and his or her co-workers. Only through such a cooperative effort can a safety program for all employees be established and preserved in their best interests.

Our Objective is a Safety and Health Program that will reduce the number of injuries and illnesses to an absolute minimum, not merely in keeping with, but surpassing the best safety program possible. Our goal is zero accidents and injuries.

# Steel Bar Division

HI-TECH steel bar division, is equipped with the latest modern technology and we are able to offer high quality grade 60, steel rebar / round, flat bar and square bar to meet customer requirement.

Steel products at HI-TECH fence and steel Industry are manufactured according to ASTM A615 & SASO 2/1992 standards in the terms of chemical compositions and mechanical properties, in addition to bend and re-bend tests as shown in the table below:



Rebar /Round bar



flat bar



Square Bar

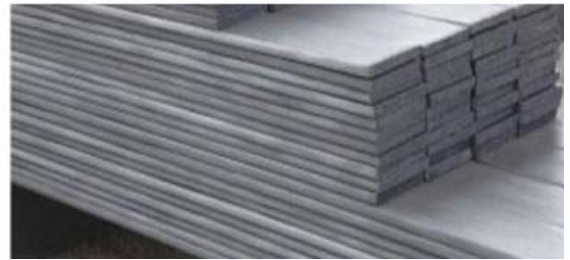

HI-TECH carries a large range of in stock material and is available over the counter. Custom orders are available with quick delivery to the site.

Equivalent To	Chemical Composition %					Mechanical Properties			Bend Test		Re-bend Test	
	C	Mn	P	S	Ceqv or CE	Yield Strength N/mm2 Min	Tensile Strength N/mm2 Min	Elongation Min %	Bending Angle Degree	Bending Diameter mm	Bending Angle Degree	Bending Diameter mm
ASTM A615 GR 60	Max	Max	Max	Max	Max	420	620	Up to 20mm-9	180	D16 Rated Dia. X 3.5		
		1.8	0.05	0.05				22&25mm-8		D18-D25 Rated Dia. X 5		
								<25mm-7		D28 Rated Dia. X 5		
Saudi Standard SASO 2/1992	0.33		0.05	0.05	0.54	460	506	12	180	Rated Dia. X3	45	Rated Dia. X5

# Steel Rebar

Rebar Range

mm 10 | 12 | 14 | 16 | 18 | 20 | 22 | 25



Nominal Diameter	Properties				
D (mm)	Weight Kgs/M	Area SQ. in.	Perim (inches)	Available Length	No. of Pcs. Per Ton
10	0.617	0.122	1.237	12	135
12	0.888	0.175	1.484	12	94
14	1.21	0.239	1.732	12	69
16	1.58	0.312	1.977	12	53
18	2	0.394	2.23	12	42
20	2.466	0.478	2.47	12	34
22	2.984	0.589	2.72	12	28
25	3.854	0.76	3.09	12	22

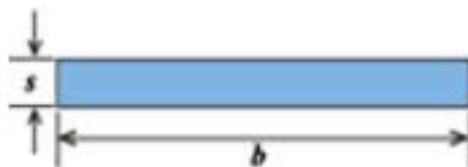
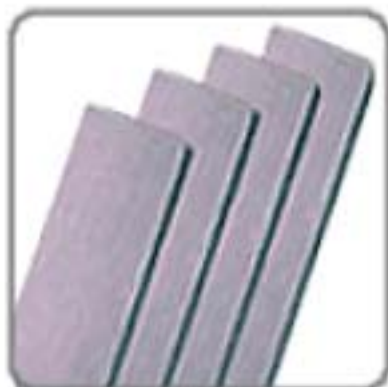

Sizes: 60 mm to 300 mm

## MS Serrated Flats

HI-TECH supplies a wide range of Mild Steel (MS) Serrated Flats. MS Serrated Flats are used for manufacturing of Industrial Gratings.



# Fence Division

Fencing solutions for every type of applications are produced. Hi-tech is one of the key manufacturers known for its economical and high standard quality fencing solutions.

Products in this division include:

- Chain link fence
- Chain link fence products
- Gates
- HT wire fence for expressways
- Concertina wire or Dannert Wire
- Welded panels and wire mesh partition systems

Chain link fence is available in galvanized and PVC coated. Fence fittings, posts and rails are either powder coated or heavy PVC coated.

Providing customized and innovative solutions in the local market, while keeping in line with international standards has generated great customer satisfaction. With this customer satisfaction, Hi-tech has expanded its customer base rapidly and now has presence in both regions of KSA.

With its resources growing monthly, Hi-Tech is projected to achieve sales in excess of more than 50 Million SAR in 2014 and will continue to grow in the coming years.



# Fence Division

At Hi-Tech Fence & Steel Industry, having years of unparalleled experience in the production of Chain Link Fence solutions.

Our fence solutions are broken down into the following categories;

- Residential Fence
- Fencing for Stadiums
- Airports
- Integrated Security Project
- Perimeter Fence
- Utility Companies (SWCC)
- Government Entities - National Guard, MODA, etc..
- ARAMCO
- SEC
- GSM site Perimeter Fence (for STC, Mobily, Zain, etc..)
- Sub Station Fencing for SCECO, Marafiq, etc..
- Agriculture

Hi-Tech also manufactures customized fencing solutions for any special projects. Our dedicated TEAM can turn your ideas into reality within 24hrs.

Our end to end manufacturing, large fabrication facility, products and our dedication to carry a wide range of inventory of special fence parts makes us one of the leaders in the Kingdom. Hi-Tech Steel & Fence is one of the Industry leaders and an ideal supplier for all your fencing projects.



# Fence Division

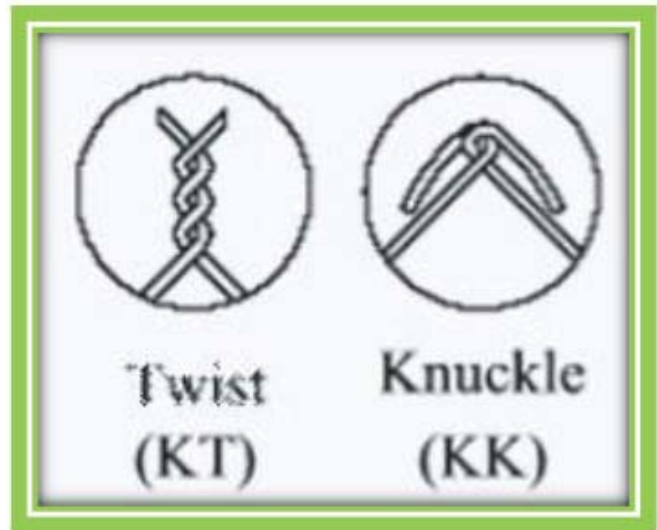
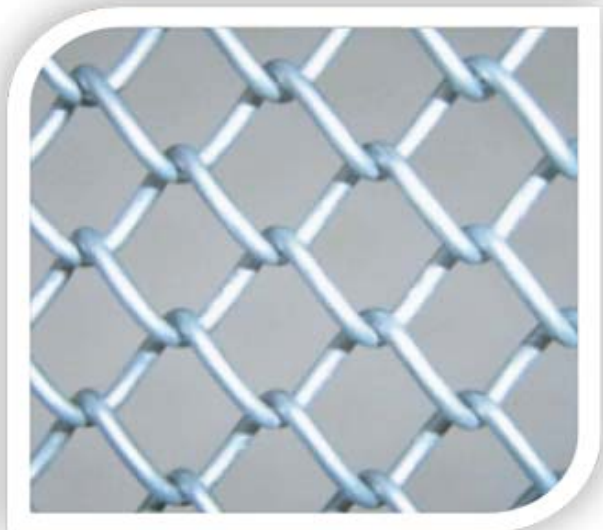

## MESH SLOTS DIAMOND SHAPE

- o 25X25mm
- o 50X50mm
- o 60X60mm
- o 70X70mm

## Wire Sizes (Diameter)

GLALVANIZED	PVC COATED
<b>2.5mm</b>	<b>Core wire dia 2.30/3.20 mm outside dia.</b>
<b>3.0mm</b>	<b>Core wire dia 2.50/3.55 mm outside dia.</b>
<b>3.5mm</b>	<b>Core wire dia 3.55/4.76 mm outside dia.</b>
<b>3.6mm</b>	<b>Core wire dia 3.76/4.88 mm outside dia.</b>
<b>4.5mm</b>	
<b>OR upon customer request</b>	<b>OR upon customer request.</b>

## MESH HEIGHT

- o From 500 MM to 4000MM

## Mesh WIRE ROLL LENGTH

- o 15, 20&25 Meters each rolls

## TOP AND BOTTOM

- o ENDING SHAPE (SELVAGE)

For more details and enquiries, kindly contact us.



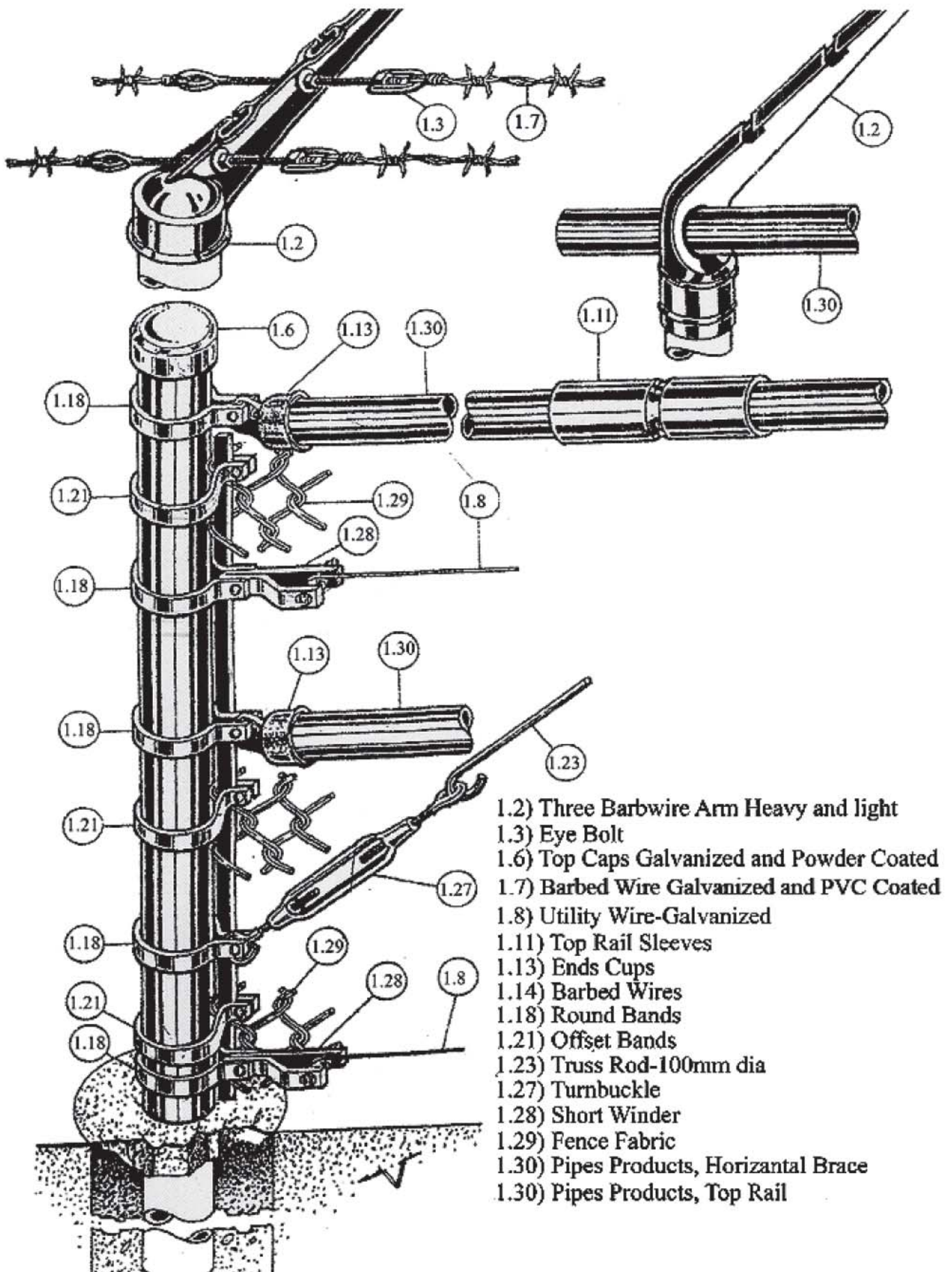

# Fence Division





# Fence Division

## Fence Accessories I

1.1) Six-Wire "V" Barbwire Arms (Galv. Or Painted)		1.2) Three-Wire 45° Barbwire Arm Heavy and light		1.3) Eye Bolt		1.4) Wall Barbwire Attachment (Galv. Or Painted)	
							
Part No.	Size	Part No.	Size	Part No.	Size	Part No.	Size
FM-BAP-2V	Fits 2" O.D. Post, 1-5/8" Top Rail"	FM-BAP-2	Fits 2" O.D. Post, 1-5/8" Top Rail"	FM-EB		FM-	
FM-BAP-25V	Fits 2-1/2" O.D. Post, 1-5/8" Top Rail"	FM-BAP-25	Fits 2-1/2" O.D. Post, 1-5/8" Top Rail"				





1.5) Nuts & Bolts		1.6) Top Caps Galvanized and Powder Coated		1.7) Barbed Wire-Galvanized and PVC coated		1.8) Utility Wire-Galvanized	
							
Part No.	Size	Part No.	Size	Part No.	Size	Part No.	Size
FM-NB		FM-TC		FM-BW-Glv		FM-UW-Glv	
				FM-BW-Pvc		FM-UW-Pvc	

1.9) Galvanized-End Rail Clamp		1.10) Galvanized-Line Rail Clamp		1.11) Top Rail Sleeves		1.12) Expansion Spring	
							
Part No.	Size	Part No.	Size	Part No.	Size	Part No.	Size
FM-GBC-133	1-3/8" x 1-3/8"	FM-LRC-133	1-3/8" x 1-3/8"	FM-SL-136	1-3/8" x 6"	FM-SPR-15	Fits 1-5/8" Sleeve
FM-GBC-153	1-5/8" x 1-3/8"	FM-LRC-153	1-5/8" x 1-3/8"	FM-SL-156	1-5/8" x 6"		

## Fence Accessories 2

1.17) Tubular Post Anchor		1.18) Round Bands		1.19) 90° Brace Bands		1.20) 180° Brace Bands	
							
<b>Part No.</b>	<b>Size</b>	<b>Part No.</b>	<b>Size</b>	<b>Part No.</b>	<b>Size</b>	<b>Part No.</b>	<b>Size</b>
FM-SPA-15	1-5/8"	FM-RBF-13	1-3/8"	FM-CBB-2	2"	FM-CBB-2	2"
FM-SPA-2	2"	FM-RBF-15	1-5/8"	FM-CBB-25	2-1/2"	FM-CBB-25	2-1/2"

1.21) Offset Bands		1.22) Truss Rod Tightness		1.23) Truss Rod-100mm dia		1.24) Tension Bar	
							
<b>Part No.</b>	<b>Size</b>	<b>Part No.</b>	<b>Size</b>	<b>Part No.</b>	<b>Size</b>	<b>Part No.</b>	<b>Size</b>
FM-OFB-13		MF-TRT-38	For 3/8" diameter truss rods	MF-TR-11		FM_TB72	
FM-OFB-15				FM-TR-15			

1.25) Gate Rail		1.26) Gate Lock Rod		1.27) Turnbuckle		1.28) Short Winder	
							
<b>Part No.</b>	<b>Size</b>	<b>Part No.</b>	<b>Size</b>	<b>Part No.</b>	<b>Size</b>	<b>Part No.</b>	<b>Size</b>
FM_GR-4	5mmX50mm X1900cm	FM_GLR	18mmX70cm	FM-TB	20cm	FM-SW	8cm

1.29) Fence Fabric		1.30) Pipes Products		1.31) Industrial Gates		1.32) Residential Gates	
							
<b>Part No.</b>	<b>Size</b>	<b>Part No.</b>	<b>Size</b>	<b>Part No.</b>	<b>Size</b>	<b>Part No.</b>	<b>Size</b>
FM-FF-Glv		FM-PP-Glv		FM-IG-Glv		FM-RG-Glv	
FM-FF-Pvc		FM-PP-Pvc		FM-IG-Pvc		FM-RG-Pvc	



# Fence Division > Concertina Wire (Coils)

Concertina wire is supplied typically in single coils or crossed spiral coils. We at Hi-Tech produce razor type barbed wire in concertina coils or straight lines.

Blade types and specifications vary according to the customers' requirements. Concertina wire (coil) is made by stainless steel sheets and galvanized high tensile claps.

It has a beautiful crossing outlook and it is suitable for uses after extending, making it an ideal security fencing with great anti-climb and anti-cutting property. Standard materials for razor type barbed wire are either galvanized or stainless steel.

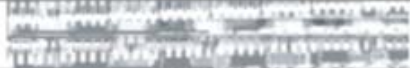
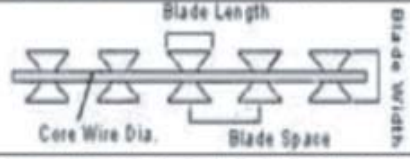
## Specification Razor Blade Specification

Reference Number	Blade Style	Thickness	Wire Dia	Barb Length	Barb Width	Barb spacing
BTO-12		0.5 ±0.05	2.5 ±0.1	10 ±1	13 ±1	26±1
BTO-18		0.5 ±0.05	2.5 ±0.1	15 ±1	15 ±1	33±1
BTO-22		0.5 ±0.05	2.5 ±0.1	22 ±1	15 ±1	34±1
CBT-65		0.6 ±0.05	2.5 ±0.1	65 ±2	21 ±1	100±2

Barbed Tape Concertina (BTC); Barbed Tape Obstacle (BTO) Standard materials are either galvanized or stainless steel. Standard packages products are shown in the tables above, special specifications available on request.

## Barbed Tape Wire Specification

Outside Diameter	No. of Loops	Standard Length per Coil	Type	Notes
450mm	33	8M	CBT-65	Single coil
500mm	41	10M	CBT-65	Single coil
700mm	41	10M	CBT-65	Single coil
960mm	53	13M	CBT-65	Single coil
500mm	102	16M	BTO-10.15.22	Cross type
600mm	86	14M	BTO-10.15.22	Cross type
700mm	72	12M	BTO-10.15.22	Cross type
800mm	64	10M	BTO-10.15.22	Cross type
960mm	52	9M	BTO-10.15.22	Cross type

Barbed Tape Concertina (BTC); Barbed Tape Obstacle (BTO) Standard materials are either galvanized or stainless steel. Standard packages products are shown in the tables above, special specifications available on request.

## Fence Division > Welded Panel Fence

We at Hi-Tech are manufacturing Welded Panel Fence Systems. The system of mesh panels consists of VEGA B panels and three types of posts: Alfa, Beta and Gamma. This type of fences is widely used to secure parks, public utility buildings, supermarkets, factories and sport centers.



# Fence Division > Welded Panel Fence

The system of fences with mesh panel fences system mounted on the Alfa, Beta and Gamma posts.  
Panel dimensions:

large meshes 50 x 200 [mm]

small meshes 50 x 50 [mm]

wire diameter 5 [mm]

Height of the panel [mm]	Width of the panel [mm]	Length of the post [mm]	Section of the post		
			Alfa	Beta	Gamma
1030	2500	2	60 x 40	60 x 40	65 x 42
1230	2500	2	60 x 40	60 x 40	65 x 42
1530	2500	3	60 x 40	60 x 40	65 x 42
1730	2500	3	60 x 40	60 x 40	65 x 42
2030	2500	4	60 x 40	60 x 40	65 x 42
2230	2500	4	60 x 40	60 x 40	65 x 42
2430	2500	4	60 x 40	60 x 40	65 x 42

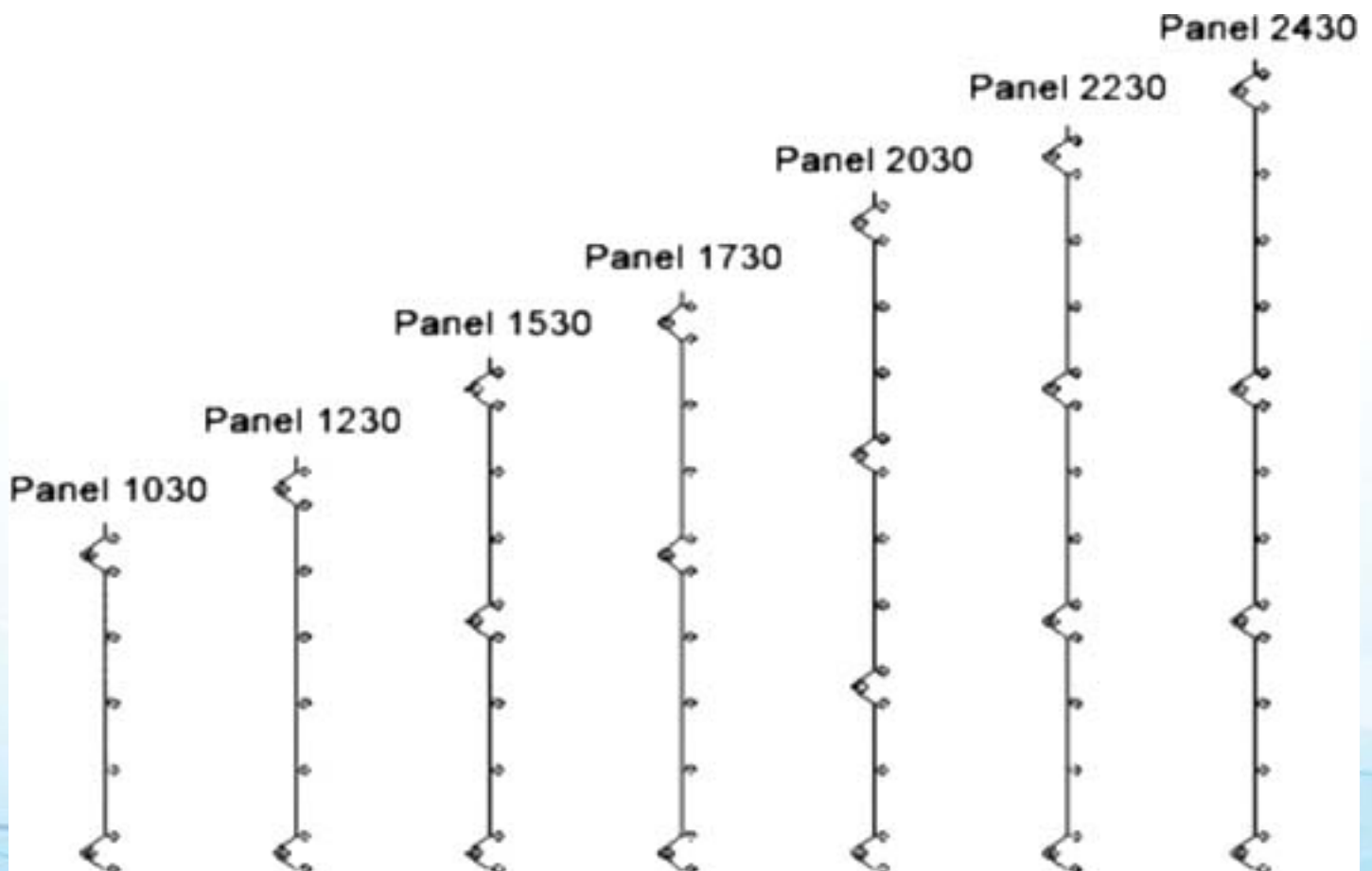

# Fence Division > Welded Panel Fence

The panel is pressure welded of single steel rods (horizontal and vertical). Thanks to bending, it keeps rigid and requires no additional frame support.

width of the panel: 2500 [mm]

the panel topped on one side with vertical wires: 30 [mm]

size of large meshes: 50 x 200 [mm]

size of small meshes: 50 x 50 [mm]

diameter of the wire: 5 [mm]

height of the panel: 1030, 1230, 1530, 1730, 2030, 2230, 2430 [mm]



Complete easy-to- Fences with mesh panels are the system solution which includes Vega B panels, posts and wickets, residential or industrial gates, filled with VEGA B mesh panel. The modular structure of the mesh panels allows you to fit the line of the fence to different topographic layouts assemble system.

Double Surface Protection:

Double surface protection (DUPLEX system) gives it the high level of protection and guarantees long-term use. Fences with mesh panels may be also available only in the galvanized version, i.e. without polyester coating.

Colors:

A wide range of colours allows you to fit colours of the fence to wood joinery or finish elements of the building.

# Fence Division > Wire Mesh Partition System

Wire mesh partitions are perfect for most Tool room, GSM Core Stock Rooms, Departmental Divisions and other restricted areas.

At Hi-Tech, the Security Cages Wire Mesh partitions can also be custom made to order by our design engineers to fit any requirements.

Wire Mesh Partitions non-bearing panels, Wire Mesh Partition panels are interchangeable and can be rapidly adapted to any need. Our Wire Mesh Partitions allow for maximum air circulation, diffuses lighting for better illumination and won't obstruct fire hose stream.

Wire Mesh Partitions are the ideal solution for any secure environment. Panels, doors and service windows can be arranged in any combination. They are attractive, economical, and quick to install and permit expansion at any time.

We are offering

- Wire Mesh Partitions
- Wire Mesh Railing Infill panels
- Wire mesh Window Guards
- Woven Wire products

Finish: Electro statically applied enamel paint (Standard Colors: Gray and Black) or hot dipped galvanized.



# Fence Division > PIPES

Hi Tech Steels Industries are manufacturing Black & Hot Dip Galvanized steel pipes conforming to ASTM A53 GRADE A & G SCH-40 and EN 10255:2004 Standards. The technical details are as follows

المواصفات الفنية للمواسير الصلب السوداء و المجلفنه على الساخن المطابقه للنظام الأمريكى (ASTMA53) درجه (A,G) - جدول 40

## TECHNICAL DATA OF BLACK AND HOT DIP GALVANIZED STEEL PIPES CONFORMING TO ASTM A 53 GRADE A & G SCH-40

NOMINAL PIPE SIZE		OUTSIDE DIAMETER STANDARD		WALL THICKNESS STANDARD		WEIGHT OF BLACK PIPES PLAIN END				TEST PRESSURE				SOCKET DIMENSIONS				NO OF PCS PER
DNCH	MM	DNCH	MM	DNCH	MM	KG/MTR	MBR/TON	LB/FT	FT/TON	GRADE A PSI	GRADE A KPA	GRADE B PSI	GRADE B KPA	MIN OUTSIDE DIA INCH	MIN OUTSIDE DIA MM	MIN LENGTH INCH	MIN LENGTH MM	LBFT
1/2	15	0.940	21.3	0.109	2.77	1.27	787	0.85	2583	700	4800	700	4800	1.063	27.0	1.500	38.1	120
3/4	20	1.050	26.7	0.113	2.87	1.69	292	1.13	1941	700	4800	700	4800	1.313	33.4	1.563	39.7	84
1	25	1.315	33.4	0.133	3.38	2.50	400	1.68	1312	700	4800	700	4800	1.576	40.0	1.938	49.2	60
1.1/4	32	1.660	42.2	0.140	3.56	3.39	295	2.27	968	1200	8300	1300	9000	1.900	48.3	2.000	50.8	42
1.1/2	40	1.900	48.3	0.145	3.68	4.05	247	2.72	810	1200	8300	1300	9000	2.200	55.9	2.000	50.8	36
2	50	2.375	60.3	0.154	3.91	5.44	184	3.66	603	2300	15900	2500	17200	2.750	69.8	2.063	52.4	26
2.1/2	65	2.875	73.0	0.203	5.16	8.63	116	5.80	380	2500	17200	2500	17200	3.250	82.5	3.063	77.8	18
3	80	3.500	88.9	0.216	5.49	11.29	89	7.58	291	2220	15300	2500	17200	4.000	101.6	3.188	81.0	14
3.1/2	90	4.000	101.6	0.226	5.74	13.57	74	9.12	242	2030	14000	2370	16800	4.625	117.3	3.313	84.1	12
4	100	4.500	114.3	0.237	6.02	16.07	62	10.80	204	1900	13100	2210	15200	5.000	127.0	3.438	87.3	10
5	125	5.563	141.3	0.258	6.55	21.77	46	14.63	151	1670	11500	1950	13400	6.296	159.9	3.688	93.7	7
6	150	6.625	168.3	0.280	7.11	28.26	35	18.99	116	1520	10500	1780	12300	7.390	187.7	4.938	125.4	7
8	200	8.625	219.1	0.322	8.18	42.55	24	28.58	79	1340	9200	1570	10800	--	--	--	--	--

## التركيب الكيميائى

### CHEMICAL COMPOSITION (% MAS)

ELEMENT →	Carbon C	Manganese Mn	Phosphorus P	Sulphur S	Copper Cu	Nickel Ni	Chromium Cr	Molybdenum Mo	Vanadium V
GRADE-A	0.25	0.95	0.05	0.045	0.40	0.40	0.40	0.15	0.08
GRADE-B	0.30	1.20	0.05	0.045	0.40	0.40	0.40	0.15	0.08

## المعالجه الحراريه

HEAT TREATMENT - Weld seam of the ERW pipe in GRade - B shall be heat treated after welding to a minimum temperature of 1000°F (540°C) so that no untempered martensite remains.



المواصفات الفنية للمواسير السوداء و المجلفنه - من الصلب مطابقه للنظام الاوربي (10255,2004)

## TECHNICAL DATA OF BLACK AND GALVANIZED STEEL PIPES CONFORMING TO EN 10255:2004

CLASS	SIZE		OUTSIDE DIAMETER				WALL THICKNESS		WEIGHT OF BLACK PIPES						WEIGHT OF GALVANIZED PIPES (CALCULATED)						NO OF PIPES PACKED PER STANDARD BUNDLE TONNE APPROX
			MAX		MIN				PLAIN ENDED			SCREWED & SOCKETED			PLAIN ENDED			SCREWED & SOCKETED			
	DN	Specified OD	Inch	mm	Inch	mm	Inch	mm	Kg/Mtr	mtr/ton	ft/ton	Kg/Mtr	mtr/ton	ft/ton	Kg/Mtr	mtr/ton	ft/ton	Kg/Mtr	mtr/ton	ft/ton	
TYPE L2	1/2	21.3	0.843	21.4	0.827	21.0	0.079	2.00	0.947	1056	3464	0.956	1046	3432	0.995	1005	3297	1.004	996	3268	160
	3/4	26.9	1.059	26.9	1.039	26.4	0.091	2.30	1.380	725	2377	1.390	719	2360	1.441	694	2277	1.451	689	2261	110
	1	33.7	1.331	33.8	1.307	33.2	0.102	2.60	1.980	505	1657	2.000	500	1640	2.058	486	1594	2.078	481	1579	80
	1.1/4	42.4	1.673	42.5	1.650	41.9	0.102	2.60	2.540	394	1292	2.570	389	1277	2.640	379	1243	2.670	375	1229	61
	1.1/2	48.3	1.906	48.4	1.882	47.8	0.114	2.90	3.230	310	1016	3.270	306	1003	3.344	299	981	3.384	296	970	51
	2	60.3	2.370	60.2	2.346	59.6	0.114	2.90	4.080	245	804	4.150	241	791	4.223	237	777	4.293	233	764	37
	2.1/2	76.1	2.992	76.0	2.961	75.2	0.126	3.20	5.710	175	575	5.830	172	563	5.892	170	557	6.012	166	546	27
MEDIUM SERIES	3	88.9	3.492	88.7	3.461	87.9	0.126	3.20	6.720	149	488	6.890	145	476	6.934	144	473	7.104	141	462	24
	4	114.3	4.484	113.9	4.449	113.0	0.142	3.60	9.750	103	336	10.000	100	328	10.026	100	327	10.276	97	319	16
	1/2	21.3	0.858	21.8	0.827	21.0	0.102	2.60	1.210	826	2711	1.220	820	2689	1.257	796	2610	1.266	790	2592	130
	3/4	26.9	1.075	27.3	1.043	26.5	0.102	2.60	1.560	641	2103	1.570	637	2090	1.621	617	2024	1.631	613	2012	100
	1	33.7	1.346	34.2	1.311	33.3	0.126	3.20	2.410	415	1361	2.430	412	1350	2.487	402	1319	2.507	399	1309	65
	1.1/4	42.4	1.689	42.9	1.654	42.0	0.126	3.20	3.100	323	1058	3.130	319	1048	3.199	313	1026	3.229	310	1016	51
	1.1/2	48.3	1.921	48.8	1.886	47.9	0.126	3.20	3.560	281	922	3.600	278	911	3.684	271	891	3.724	269	881	44
	2	60.3	2.394	60.8	2.350	59.7	0.142	3.60	5.030	199	652	5.100	196	643	5.172	193	634	5.242	191	626	30
	2.1/2	76.1	3.016	76.6	2.965	75.3	0.142	3.60	6.420	156	511	6.540	153	502	6.612	151	496	6.732	149	487	24
	3	88.9	3.524	89.5	3.465	88.0	0.157	4.00	8.360	120	392	8.530	117	385	8.583	117	382	8.753	114	375	19
	4	114.3	4.528	115.0	4.453	113.1	0.177	4.50	12.200	82	269	12.500	80	262	12.476	80	263	12.726	79	258	14
HEAVY SERIES	5	139.7	5.543	140.8	5.453	138.5	0.197	5.00	16.600	60	198	17.100	58	192	16.938	59	194	17.438	57	188	10
	6	165.1	6.555	166.5	6.453	163.9	0.197	5.00	19.800	51	166	20.400	49	161	20.102	50	163	20.702	48	158	7
	1/2	21.3	0.858	21.8	0.827	21.0	0.126	3.20	1.440	694	2278	1.450	690	2263	1.486	673	2208	1.495	669	2195	110
	3/4	26.9	1.075	27.3	1.043	26.5	0.126	3.20	1.870	535	1754	1.880	532	1745	1.930	518	1700	1.940	515	1691	80
	1	33.7	1.346	34.2	1.311	33.3	0.157	4.00	2.930	341	1120	2.950	339	1112	3.015	332	1088	3.035	329	1081	55
	1.1/4	42.4	1.689	42.9	1.654	42.0	0.157	4.00	3.790	264	866	3.820	262	859	3.897	257	842	3.927	255	835	44
	1.1/2	48.3	1.921	48.8	1.886	47.9	0.157	4.00	4.370	229	751	4.410	227	744	4.492	223	730	4.532	221	724	37
	2	60.3	2.394	60.8	2.350	59.7	0.177	4.50	6.190	162	530	6.260	160	524	6.330	158	518	6.400	156	513	27
	2.1/2	76.1	3.016	76.6	2.965	75.3	0.177	4.50	7.930	126	414	8.050	124	408	8.110	123	405	8.230	122	399	20
	3	88.9	3.524	89.5	3.465	88.0	0.197	5.00	10.300	97	319	10.500	95	312	10.510	95	312	10.680	94	307	16
4	114.3	4.528	115.0	4.453	113.1	0.213	5.40	14.500	69	226	14.800	68	222	14.774	68	222	15.024	67	218	12	
5	139.7	5.543	140.8	5.453	138.5	0.213	5.40	17.900	56	183	18.400	54	178	18.238	55	180	18.738	53	175	10	
6	165.1	6.555	166.5	6.453	163.9	0.213	5.40	21.300	47	154	21.900	46	150	21.702	46	151	22.302	45	147	7	



Below listed drawings could be downloaded from our website or send us email using contacts given on the last page of this brochure

## Fencing System Standards Drawings:

### BS Standards

- BS 2000/2400-TT (CLASS-DA-DB & DC)
- BS 2000/2400-TR (CLASS-DA-DB & DC)
- BS 2000/2400-B3TT (CLASS-DA-DB & DC)
- BS 2000/2400-B3TR (CLASS-DA-DB & DC)
- BS 2000/2400-B6TT (CLASS-DA-DB & DC)
- BS 2000/2400-B6TR (CLASS-DA-DB & DC)
- BS 2000/2400-B8TT (CLASS-DA-DB & DC)
- BS 2000/2400-B8TR (CLASS-DA-DB & DC)

### SAUDI ARAMCO Standards

- Saudi Aramco Security Fence Type - 1
- Saudi Aramco Security Fence Type - 2
- Saudi Aramco Security Fence Type - 3
- Saudi Aramco Security Fence Type - 4
- Saudi Aramco Security Fence Type - 5

### SSD Standards

- SSD Standard Detail 1
- SSD Fence Detail 2
- SSD Fence Detail 3

### Gates

### Fence for Roads

- Agriculture Area Fence Section
- Rural Area Fence Section

# Misc. Steel Product division

Hi-Tech Fence & Steel Ind. is well suited to handle your miscellaneous steel needs; we want to give you some idea of the scope of our steel fabrication abilities. Here are just a few of the items that we've used our miscellaneous steel experience to create.

- Handrails
- Bridge Rails
- Platforms
- Cage Ladders
- Stairs
- Trash Screen
- Canopies
- Traffic Barriers
- Bollards
- Wire mesh Partition system
- Steel grill – Grating
- Checkered plats
- GSM Antenna bracket
- Cable tray / Cable ladder



# Misc. Steel Product division

We are also capable of providing items in a mill finish, prime painted, 2 coats painted, or galvanized finishes to meet your project's needs. We provide a cost effective, quality product, in timely manner

At Hi-Tech, we see Miscellaneous Steel not just as a necessary portion of completing a project. For us, it is an opportunity to create an actual, tangible product based on an idea, concept or drawing from our customers. And that's something we enjoy doing, making our customers expectation come to reality.



**Steel Trash Screen**



**Canopy, Bollards, Railing**



**Steel pre-cast conc. Mold**



**Wire mesh Partition System**

# Misc. Steel Product division

Hi-Tech's experienced staff is experts at looking at the unique needs of each of our clients and using our fabrication equipment, CAD detailing, and 3D modelling software to create a customized miscellaneous steel solution. Whatever your needs, we have the experience, technology, and drive, to make sure that we get your project completed.



# Misc. Steel Product division

## Trusted Steel Experts

No matter what industry you're working in, we have the know-how to get your job done on time. We know the industry standards you need to meet to complete your project. Hi-Tech has fabricated thousands of products for the Public, Industrial, Commercial, Architectural and Government Organizations assisting them in their miscellaneous metal requirements. We are excited about the opportunity to put our company's experienced and dedicated TEAM to work for you.



## Our Customers & Partners

Below is the partial list of clients. For the updated list of clients and approvals, kindly contact us.





# Hi-Tech Steel and Fence Industries

## SALES STEEL

Hi-Tech Steel and Fence Industries  
PO BOX 325752  
Riyadh 11371  
Saudi Arabia  
Tel: +966 11 2064979 ext. \*\*\*\*  
Fax: +966 11 2914419  
Email: Sales\_Steel@nartel-ksa.com

## SALES FENCE

Hi-Tech Steel and Fence Industries  
PO BOX 325752  
Riyadh 11371  
Saudi Arabia  
Tel: +966 11 2064979 ext. \*\*\*\*  
Fax: +966 11 2914419  
Email: Sales\_Fence@nartel-ksa.com

## Production

Hi-Tech Steel and Fence Industries  
PO BOX 325752  
Riyadh 11371  
Saudi Arabia  
Tel: +966 11 2064979 ext. \*\*\*\*  
Fax: +966 11 2914419  
Email: Production@nartel-ksa.com

## Accounting

Hi-Tech Steel and Fence Industries  
PO BOX 325752  
Riyadh 11371  
Saudi Arabia  
Tel: +966 11 2064979 ext. \*\*\*\*  
Fax: +966 11 2914419  
Email: Accounting@nartel-ksa.com

